

REV	DATE	DESCRIPTION	BY	CHKD
00				
D		REVISED PER ESD-08-008233	B/JAN/07	ZURWILK

4 3 2 1

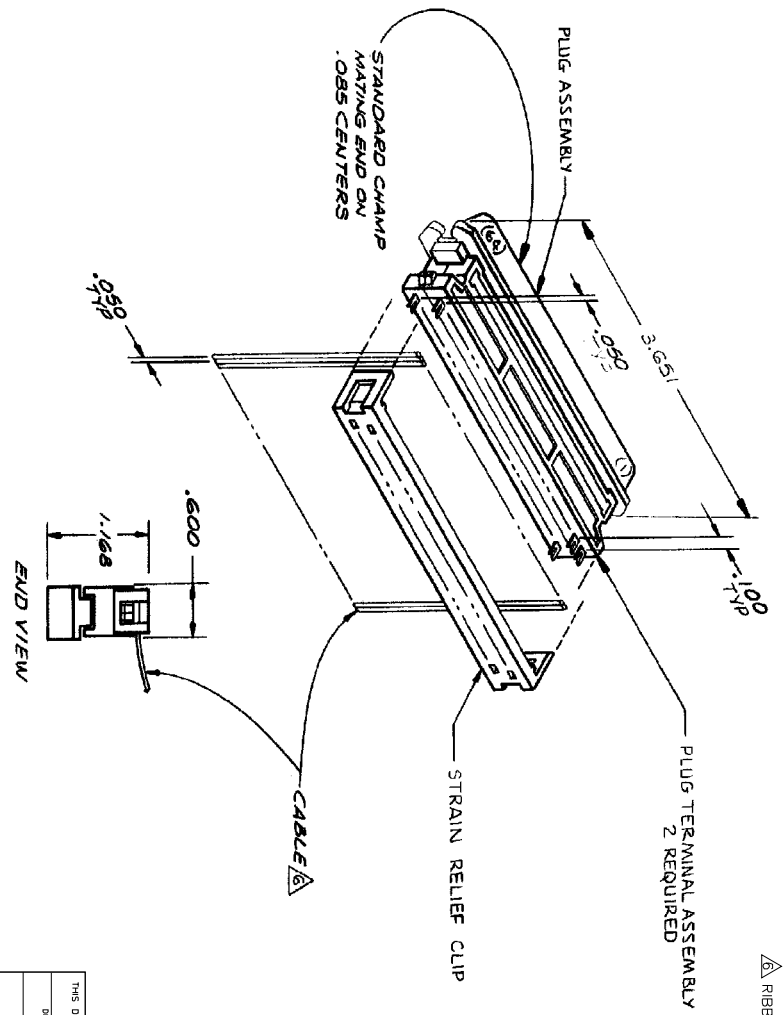

1. THE CONTACT SURFACES OF THE TERMINALS ARE COATED WITH LUBRICANT.
2. MATERIAL:
HOUSING & STRAIN RELIEF CLIP - THERMOPLASTIC (BLACK)
TERMINALS - HIGH STRENGTH COPPER ALLOY PLATED WITH .000030 MIN GOLD, OR GOLD FLASH OVER .000030 MIN PALLADIUM NICKEL, ON CONTACT MATING SURFACE. GOLD FLASH ON TERMINATING END. .000050 MIN NICKEL UNDERPLATE OVER ENTIRE TERMINAL.
3. STRAIN RELIEF CLIP SHIPPED UNASSEMBLED.
4. WIRE SIZE: 28 AWG STRANDED OR 30 AWG SOLID COPPER RIBBON CABLE.

△ ALL DIMENSIONS SHOWN ARE FOR REFERENCE ONLY UNLESS OTHERWISE SPECIFIED.
△ RIBBON CABLE SHALL BE FURNISHED BY CUSTOMER.

THIS DRAWING IS A CONTROLLED DOCUMENT		DATE: 12-27-79		BY: STEPHEN DOSS	
DRAWING NO. 552933-1		REV. 00		DATE: 12-27-79	
DESCRIPTION: PLUG KIT, 64 POSITION, RIBBON CABLE		DRAWN BY: RICH		CHECKED BY: RICH	
PART NO. 552933		MATERIAL: THERMOPLASTIC		FINISH: .000030 MIN GOLD	
CUSTOMER DRAWING: A2100779		SCALE: 1" = 1"		REV. D	